

INSTALLATION INSTRUCTIONS

77-6012

NISSAN / INFINITI

2005-09 ARMADA

2004 PATHFINDER ARMADA

2004-09 TITAN

2004-09 QX56

V8 5.6L

NOTE: EO# D-269-34 ONLY
APPLIES TO 2004-07 MODELS

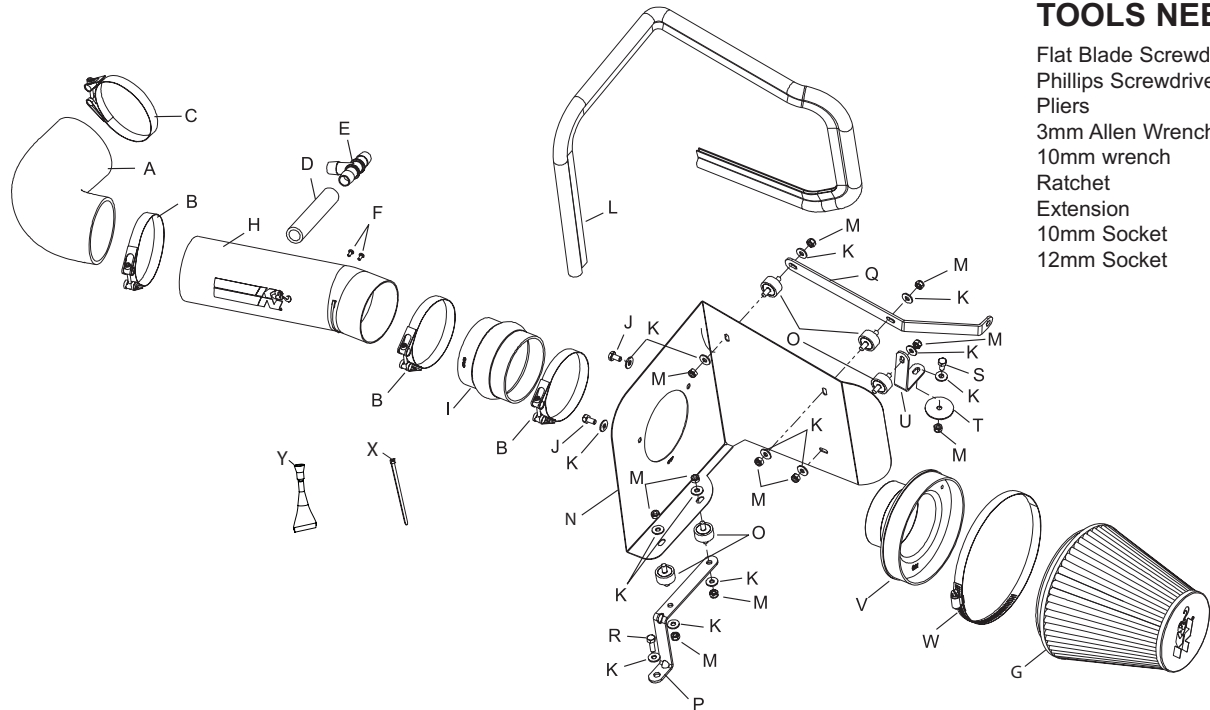

TOOLS NEEDED:

- Flat Blade Screwdriver
- Phillips Screwdriver
- Pliers
- 3mm Allen Wrench
- 10mm wrench
- Ratchet
- Extension
- 10mm Socket
- 12mm Socket

PARTS LIST:

Desc.	Qty.	Part #	Desc.	Qty.	Part #	Desc.	Qty.	Part #
A Hose, 3-1/4" to 3-1/2"	1	084089	J Bolt, M6-1.0 x 12mm L, Hex	2	07727	S Bolt, M6-1.0 x 20mm L, Hex	1	07795
B Hose Clamp, #56	3	08620	K Washer, 6mm Flat	14	08269	T Washer, Fender	1	21711
C Hose Clamp, #52	1	08610	L Edge Trim, 3/4" Bulb, 48"L.	1	102485	U Bracket, "L"	1	010031
D Hose, 5/8"ID x 5"L.	1	08538	M Nut, 6mm Nylock	11	07512	V Adapter	1	08806
E Vent, 5/8" Hose, "T"	1	080018	N Heat Shield	1	07317	W Hose clamp, #104	1	08697
F Bolt, M4-.7 x 8mm L, C.H.A.	2	07733	O 6mm Rubber Mounted Stud	5	07027	X Cable Tie	1	21592
G Air filter	1	RC-5046	P Bracket, "Z"	1	070852	Y Loctite	1	11201
H Performance Intake Tube	1	27351	Q Bracket, Angle	1	010032			
I Hose, 3-1/2" Silicone Hump	1	084057	R Bolt, M6-1.0 x 16mm L, Hex	1	07812			

NOTE: FAILURE TO FOLLOW INSTALLATION INSTRUCTIONS AND NOT USING THE PROVIDED HARDWARE MAY DAMAGE THE INTAKE TUBE, THROTTLE BODY AND ENGINE.

TO START:

1. Turn the ignition OFF and disconnect the vehicle's negative battery cable.



2. Remove the two bolts that secure the engine cover, then, remove the engine cover as shown.



3. Disconnect the mass air sensor electrical connection as shown.

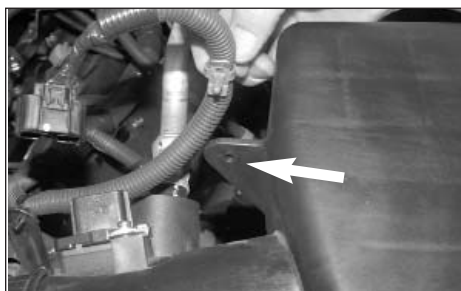

4. Unclip the mass air sensor wire harness from the tab on the air cleaner as shown.



5. Disconnect the crank case vent hoses from the intake tube resonator as shown.



6. Loosen the hose clamps, then, remove the stock intake tube as shown.



7. Unclip the air cleaner cover, then, remove the air cleaner cover as shown.

NOTE: On four wheel drive vehicles, it will be necessary to un-hook the differential vent hose from the air box lid.



8. Remove the two bolts on the air cleaner as shown.



9. Pull firmly upwards to release the air cleaner from the lower grommet as shown.

NOTE: K&N recommends that customers do not discard factory air intake.

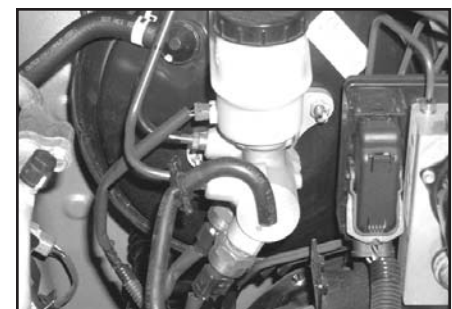

9a. On four wheel drive vehicles, secure the front differential vent tube to the front brake hardline as shown with the provided tie wrap.



10. From underneath the inner fender panel remove the plastic rivet as shown.



11. Remove the hex bolt located directly below the windshield washer reservoir as shown.



12. Remove the bolt on the ABS bracket as shown.



13. Install the provided trim seal onto the heat shield as shown.



14. Using the provided tube of Loc-Tite, apply two drops to the hex bolts and secure the filter adapter to the heat shield with the provided hex bolts and wave washers as shown.

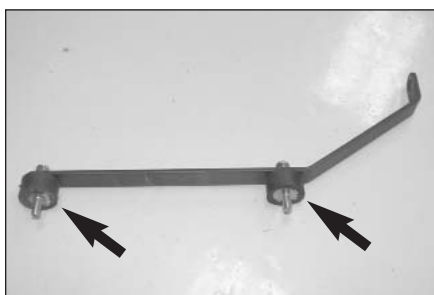

15. Install the rubber mounted studs onto the "Angle" bracket with the provided hardware as shown, but do not tighten at this time.

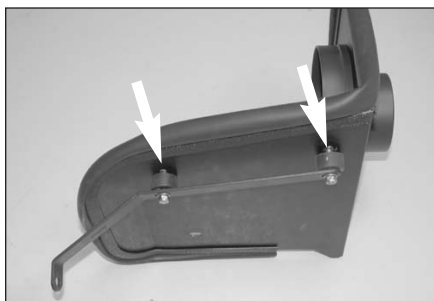

16. Install the Angle bracket onto the heat shield and secure with the provided hardware but do not tighten at this time.



17. Install the rubber mounted stud onto the "L" bracket as shown, but do not tighten at this time.

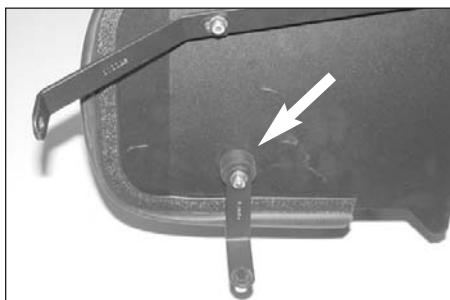

18. Install the "L" bracket onto the heat shield as shown, but do not tighten at this time.

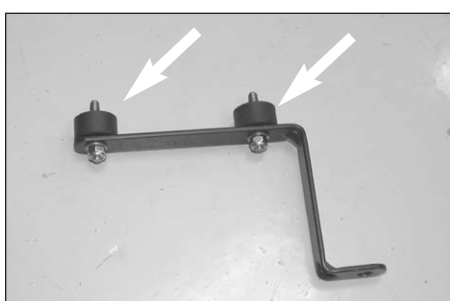

19. Install the rubber mounted studs onto the "Z" bracket and firmly tighten with the provided hardware as shown.

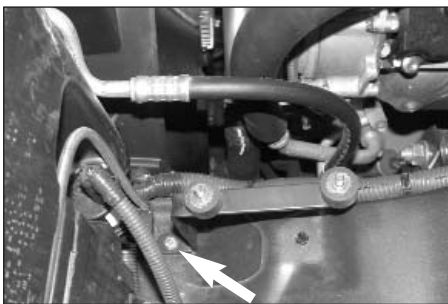

20. Install the "Z" bracket into the vehicle and secure it to the threaded hole from step 11 using the provided hardware as shown.



21. Install the heat shield into the vehicle and secure it to the rubber mounted studs using the provided hardware as shown, but do not tighten at this time.

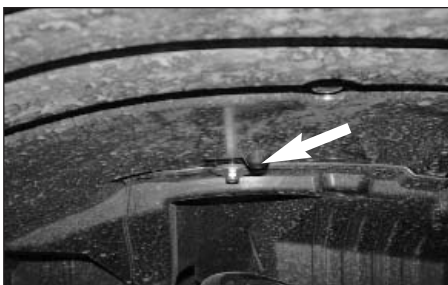
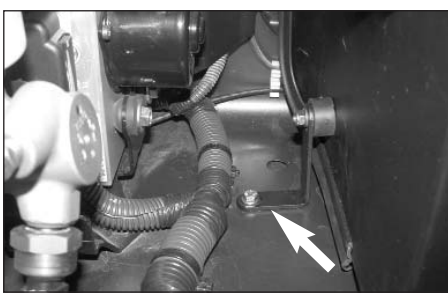

22. Secure the "L" bracket to the hole from step 10 on the inner fender panel with the provided hardware as shown.

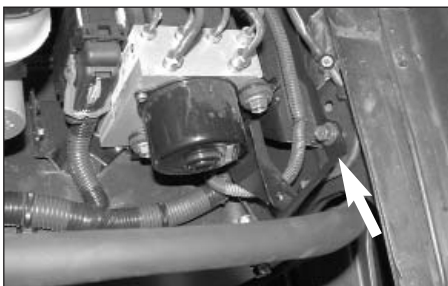

23. Using the bolt from step 12 secure the angle bracket to the ABS bracket as shown.

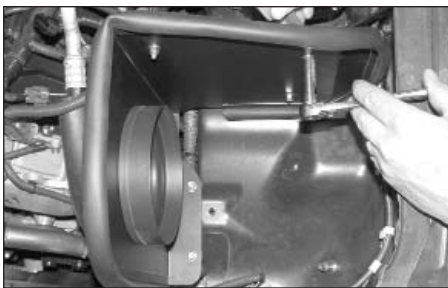

24. Adjust everything for best fit and clearance, then, tighten all hardware at this time.



25. Remove the mass air sensor from the air cleaner cover as shown.

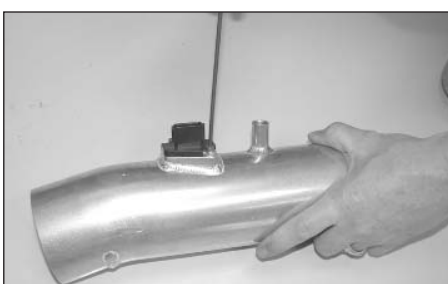

26. Install the mass air sensor into the K&N intake tube using the provided hardware as shown.



27. Slide the silicone hump hose and hose clamps onto the K&N intake tube as shown.

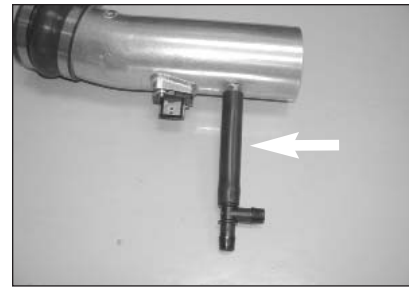

28. Install the provided silicone hose and "T" vent onto the vent on the K&N intake tube as shown.

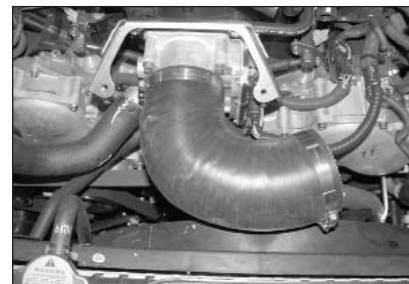

29. Slide the angled hose and hose clamps onto the throttle body, but do not tighten at this time.



30. Slide the K&N intake tube onto the filter adapter, then, slide the other end into the angle hose on the throttle body. Adjust everything for best fit, then, tighten all hose clamps as shown.



31. Reconnect the crank case vent hoses to the plastic "T" as shown.



32. Install the K&N air filter onto the air filter adapter and secure it with the provided hose clamp as shown.



33. Reconnect the mass air sensor electrical connection as shown.



34. Re-install the engine cover as shown.



35. Reconnect the negative battery cable and double check to make sure everything is tightened and properly positioned before starting the vehicle.

36. The C.A.R.B. exemption sticker, (attached), must be visible under the hood so that an emissions inspector can see it when the vehicle is required to be tested for emissions. California requires testing every two years, other states may vary.

37. It will be necessary for all K&N intake kits to be checked periodically for realignment, clearance and tightening of all connections. Failure to follow the above instructions or proper maintenance may void warranty.

ROAD TESTING:

1. Start the engine with the transmission in neutral or park, and the parking brake engaged. Listen for air leaks or odd noises. For air leaks secure hoses and connections. For odd noises, find cause and repair before proceeding. This kit will function identically to the factory system except for being louder and much more responsive.

2. Test drive the vehicle. Listen for odd noises or rattles and fix as necessary.

3. If road test is fine, you can now enjoy the added power and performance from your kit.

4. K&N suggests checking the air filter element periodically for excessive dirt build-up. When the element becomes covered in dirt (or once a year), service it according to the instructions on the Recharger service kit, part number 99-5000 or 99-5050.

FREE K&N DECAL To register your warranty, please see us online at knfilters.com/register. FREE K&N DECAL